

# HERCULES REAR WALL POLE with SafetyGrip®

SG500

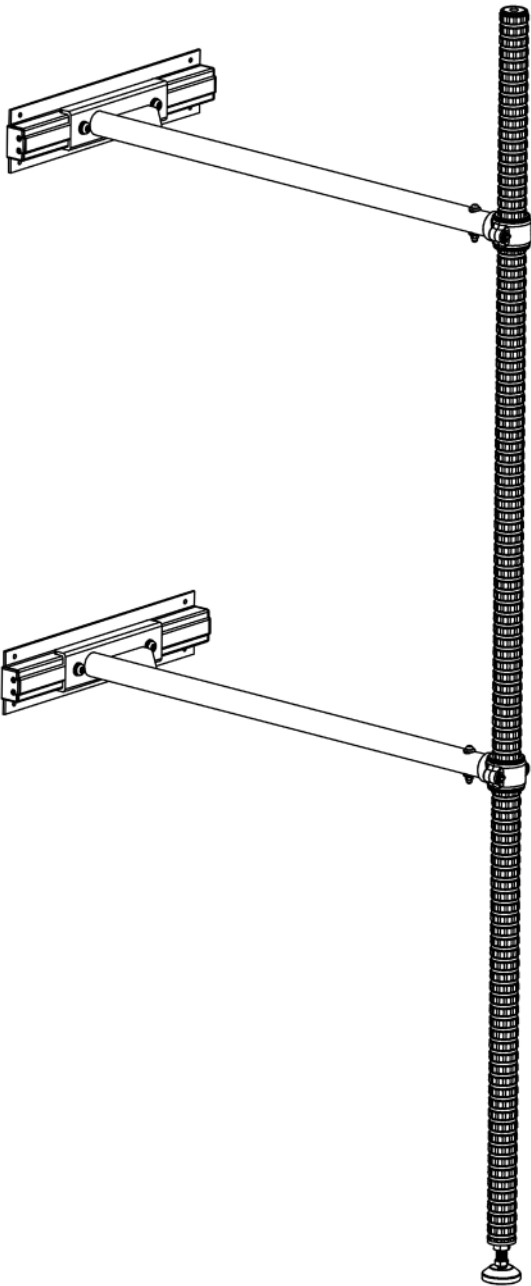

## Table of Contents

- Warnings and Cautions for Hercules Poles (2 Pages)
- Entrapment Prevention Information for Poles (2 Pages)
- Additional Warnings and Cautions (2 Pages)
- SG500 Installation Instructions (6 Pages)

## Specifications:

- Product Name: Hercules Rear Wall Mount Pole
- Product#: SG500
- Maximum User Weight: 350lbs (158kg)

# KIT CONTENTS

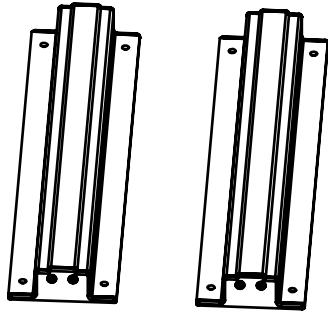

**WALL TRACKS**

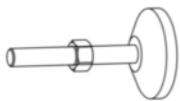

**LEVELLING FOOT**

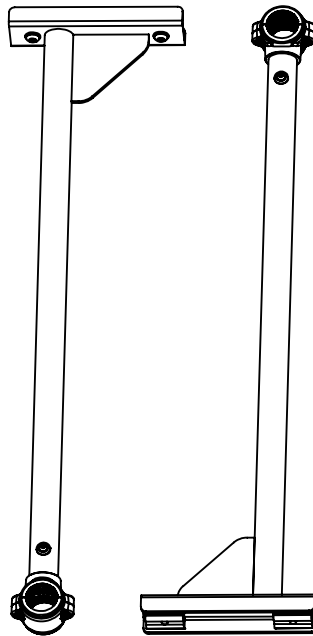

**HORIZONTAL ARMS  
with TRACK ATTACHMENTS**

(Carton 1)



**SafetyGrip POLE**

(Carton 2)

## Tools Included (Carton 1)

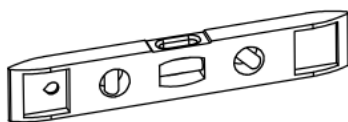

**LEVEL**



**HEX KEYS**



**12-#14 x 3" Woodscrews**

**HARDWARE**

# ASSEMBLY & INSTALLATION

## Product Information and Specifications

- The Hercules Pole feature our patented interlocking SafetyGrip® and the long-lasting protection of embedded antimicrobial AlphaSan® RC5000 silver ions powder for all parts except hardware.  
For more details about AlphaSan®: <https://www.milliken.com/en-us/businesses/chemical/product/alphasan>
- The Hercules Pole is an assistive device designed to assist with sit-up, reposition, balance, stand, or transfers.

## Tools & Hardware you will need

1. Stud Finder
2. Power Drill
3. Strong Scissors or a fine tooth saw
4. #2 & #3 Phillips Screw Driver
5. A Tape Measure and a Pencil
6. For installation into wood studs you will need a 5/32 inch (4mm) drill bit for the pilot holes.
7. For Installation into metal studs you will need 6 drywall anchor bolts for steel studs not supplied, the necessary drill bit and a tool to tighten the anchor bolts you choose.

## STEP 1: Remove End Caps & Seal from the Wall Tracks

1. Unscrew the plastic End Caps from the Wall Tracks.
2. Slide out the Wall Track Seal.
3. Put these parts and the screws to one side. You will re-assemble these later.

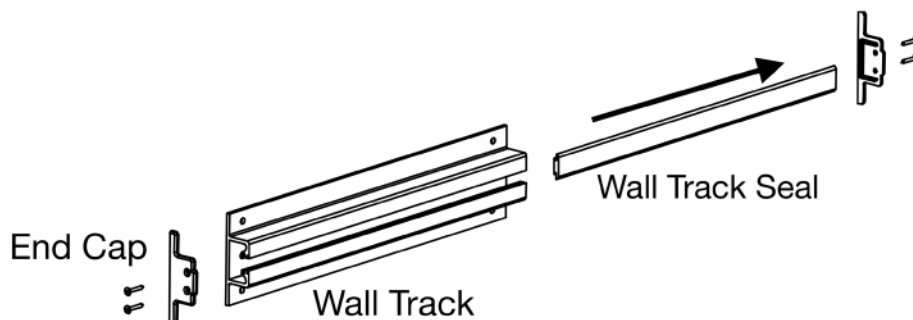

STEP 1

## STEP 2: Mount the Wall Tracks on the wall. 2a for Wood Studs. 2b for Steel Studs

### Note 1:

The Wall Tracks have 12 inches of sideways adjustment allowing you to locate the Pole anywhere you wish between the studs. If your Pole location is near the end of the Wall Tracks the Horizontal Arms can be turned either way.

### Note 2:

**IMPORTANT:** If using this pole against a bed the lower Horizontal Arm must be located at a maximum height where the gap under the Horizontal Arm to the top of the mattress is no more than 2 inches (50mm) above the top of the mattress.

Alternately the lower Horizontal Arm can be mounted at any height below the top of the mattress to within 8 inches (200mm) of the floor.

This is to prevent any possible Entrapment Hazard as described in the Entrapment Prevention Information provided. The drywall must be at least ½ inch (12mm) thick. Usually, the studs are placed 16 inches (406.4mm) on center. The Wall Track is predrilled for these centers. If your studs are on centers less than 16 inches you will have to re-drill the Wall Track with 9/32 diameter holes accordingly. If studs are on centers greater than 16", contact customer service for installation assistance.

### 2a: Installing the Wall Tracks into wood studs:

For each Wall Track, locate the stud centers at the desired height and, using a pencil, mark the wall with a line 3" long. Use care here to make sure that the wall tracks are horizontal, parallel to each other and that the ends are in line. You can use the level provided. See illustrations below.

1. Place the Wall Tracks on the wall with the Track holes on center to the marks that you have made. Use the pencil to clearly mark all the track holes through the Wall Track.
2. Remove the Wall Track from the wall
3. Pre-drill 5/32" diameter holes for the wood screws.
4. Install the Wall Tracks using the 12 - #14 x 3" long wood screws supplied.

Slide the Horizontal Arms onto the Wall Tracks - you can leave them loose at this point.

### 2b: Installing the Wall Tracks into Steel studs

For each Wall Track, locate the stud centers at the desired height and, using a pencil, mark the wall with a line 3" long.

1. Place the Wall Tracks on the wall with the Track holes on center to the marks that you have made. Use the pencil to clearly mark all the track holes through the Wall Track.
2. Remove the Wall Track from the wall.
3. Drill the correct size holes for the drywall anchor bolts that you are using
4. Install the Wall Tracks using the 6 drywall anchor bolts that you have chose to use - not supplied.

Slide the Horizontal Arms onto the Wall Tracks - you can leave them loose at this point.

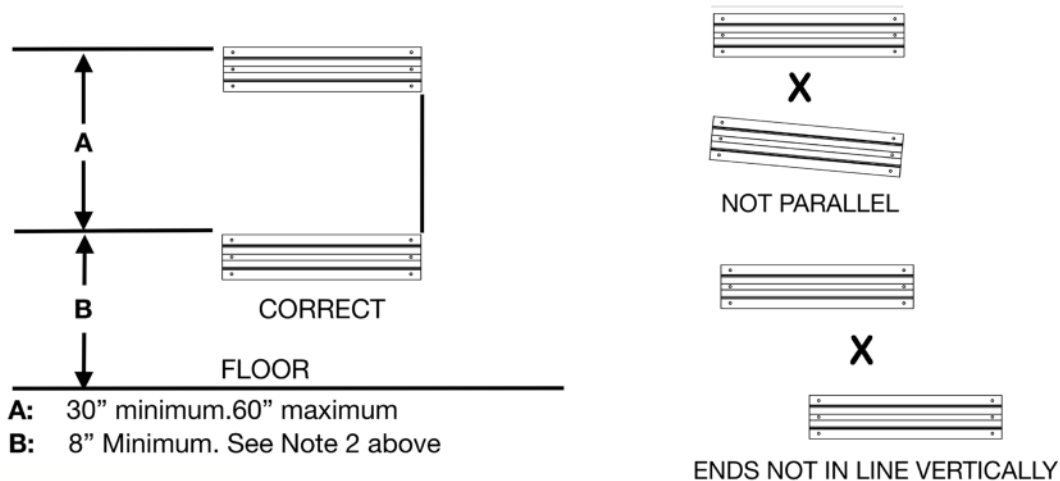

### STEP 3: Join the Pole to the Horizontal Arms

1. Remove the screws and nuts from the Pole Clamps on the ends of the Horizontal Arms. Use the Hex Key provided.
2. Stand the Pole against the opened clamp on the Horizontal Arms.
3. Re-assemble the clamp with the screws and nuts, and tighten securely.
4. Now you can tighten the screws that secure the Horizontal Walls tracks.

**Note:** Make sure that your Pole is vertical to the floor.

5. Adjust the Levelling foot until it is firmly on the floor. Tighten the locking nut on the Levelling Foot against the bottom of the Pole.

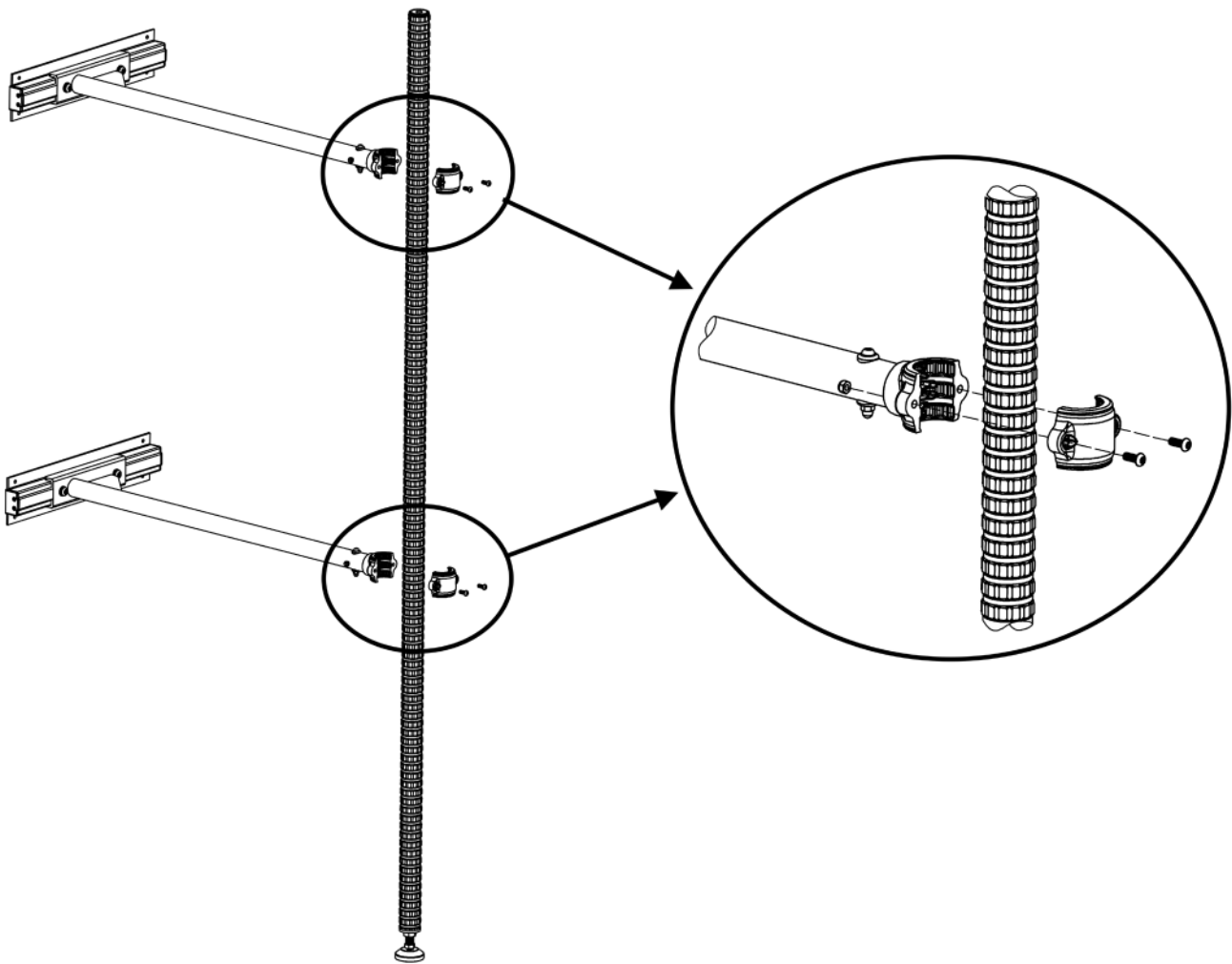

STEP 3

## STEP 4: Re-Assemble the Wall Track seal and End Caps

1. First slide the seal into one end of the Wall Track and mark the end level with the end of the Wall Track.
2. Cut the Seal to length. Strong scissors or a small saw can do this.
3. Repeat Steps 1 & 2 until the Wall Track has all the Seals inserted.
4. Screw the Wall Track plastic End Caps into the ends of the Wall Tracks.
5. Your Wall Tracks are now fully sealed.

## STEP 5: Final Checks

Make sure that all nuts, bolts and screws are securely tightened.

# MAINTENANCE AND CLEANING

**VERY IMPORTANT:** It is important to inspect the Product(s) frequently.

- Stop using immediately if damaged or broken, or if parts are missing.
- Stop using immediately if Product(s) shift out of the original installed position(s) until they are readjusted into the correct position.
- To clean, use a damp cloth with soap and water or mild household cleaner, wipe clean and dry before using.



Hartmobility reserves the right to update and revise our products. Refer to our website for the most up-to-date version of this document.