

# SafetyGrip® POLE EXERCISE ATTACHMENT CLAMPS

SG605

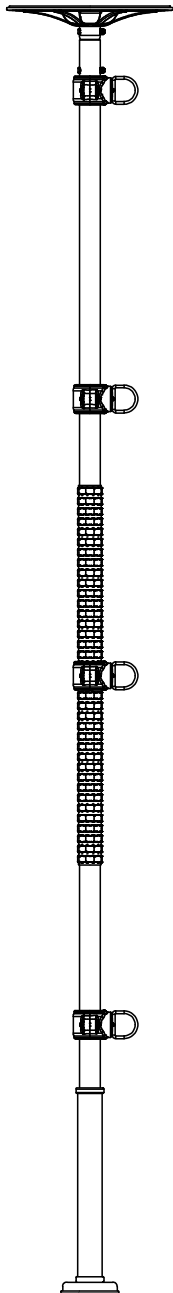

600 Series

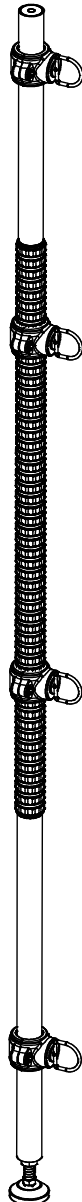

500 Series

## Table of Contents

- SG605 Installation Instruction (3 Pages)

## Specifications:

- Product Name: SafetyGrip® Pole Exercise Attachment Clamps
- Product#: SG605

## KIT CONTENTS

For regular installations you will need a Step Ladder and Safety Glasses. The Hex Key is included in this kit.

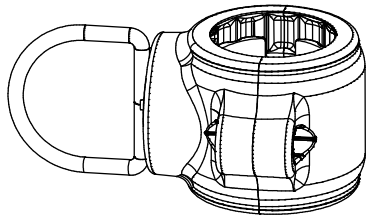

**EXERCISE CLAMP x 4**



**HEX KEY**

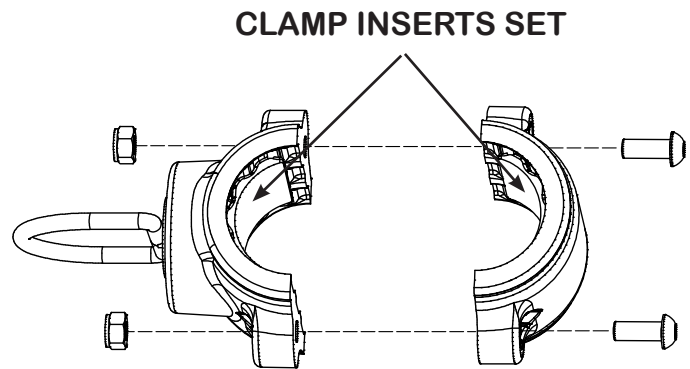

**CLAMP INSERTS SET**

## Product information

The SG605 features our patented interlocking SafetyGrip® and the long-lasting protection of embedded antimicrobial AlphaSan® RC5000 silver ions powder for all parts except hardware. For more details about AlphaSan®: <https://www.milliken.com/en-us/businesses/chemical/product/alphasan>

- The Exercise Clamps are designed to be used with all SafetyGrip® Grab Poles.
- The SG605 Exercise Clamps are compatible with all styles and types of Resistance Band and Resistance Tubing products.

## INSTALLATION

### STEP 1: Open the clamp kit

Remove the Clamp Inserts.

Open the clamps by undoing the screws and nuts using the Hex Key provided.

### STEP 2: Place the clamps where you want to use them

The Exercise Clamps that will be fitted to any part of the Pole with SafetyGrips do not need the Clamp Inserts. Remove these and discard.

The Exercise Clamps that will be fitted to any part of the plain Pole are ready to install using the Clamp Inserts.

Install all the Exercise Clamps where you want them, reinstall the screws and nuts and tighten securely using the hex key.

**Installer Note:** If you want the bottom clamp lower, slide the Cover Tube up on the Titan pole, install the clamp lower and slide the Cover Tube back down the Titan pole onto this clamp.

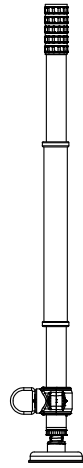

COVER TUBE

NOTE: SHOULD YOU WANT THE BOTTOM CLAMP LOWER:  
SLIDE THE COVER TUBE UP, INSTALL THE 583 CLAMP  
AT THE BOTTOM OF THE POLE AND SLIDE THE COVER  
TUBE BACK DOWN ONTO THIS CLAMP

## Maintenance

- **VERY IMPORTANT:** It is important to inspect the Product(s) frequently.
- Stop using immediately if damaged or broken, or if parts are missing.
- Stop using immediately if Product(s) shift out of the original installed position(s) until they are readjusted into the correct position.

To clean your Exercise Pole Clamps, use a damp cloth with soap and water or mild household cleaner, wipe clean and dry before using.

## Warranty

For warranty details, refer to the Warranty details on the Hartmobility Inc.

Website: [www.hartmobility.com/Warranty](http://www.hartmobility.com/Warranty) or call 1-800-998-0774 ext. 3



**Questions. Comments. Concerns.**

Contact Customer Service today.

[info@SafetyGrip.com](mailto:info@SafetyGrip.com)

[www.SafetyGrip.com](http://www.SafetyGrip.com)

[www.Hartmobility.com](http://www.Hartmobility.com)

1(800) 998-0774

Hartmobility Inc.  
424 Williamson-Zebulon Rd.  
Williamson, GA 30292

Hartmobility reserves the right to update and revise our products. Refer to our website for the most up-to-date version of this document.

Copyright © 2025 Hartmobility Inc. All Rights Reserved.

