

SafetyGrip® GRAB POLE FOR ANGLED CEILINGS

SG615 Titan Series

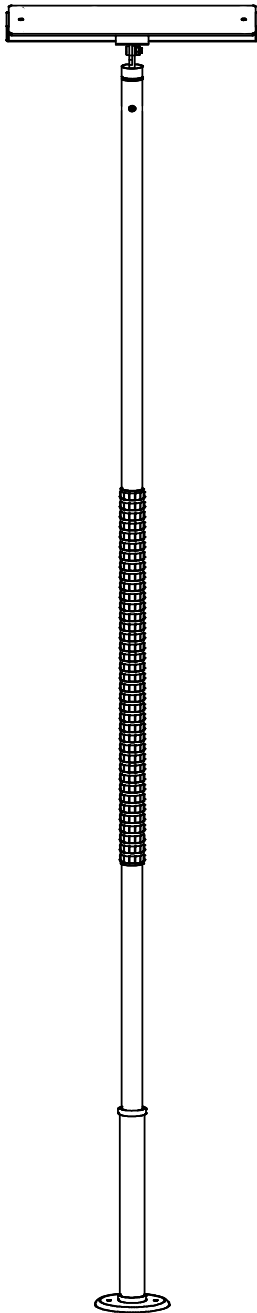

Table of Contents

- Warnings and Cautions for Grab Poles (2 Pages)
- Additional Warnings and Cautions for Bedside Poles (2 Pages)
- SG615 Installation Instruction (7 Pages)

Specifications:

- Product Name: SafetyGrip® Grab Pole For Angled Ceilings
- Product#: SG615
- Maximum User Weight: 300lbs (136kg)



KIT CONTENTS

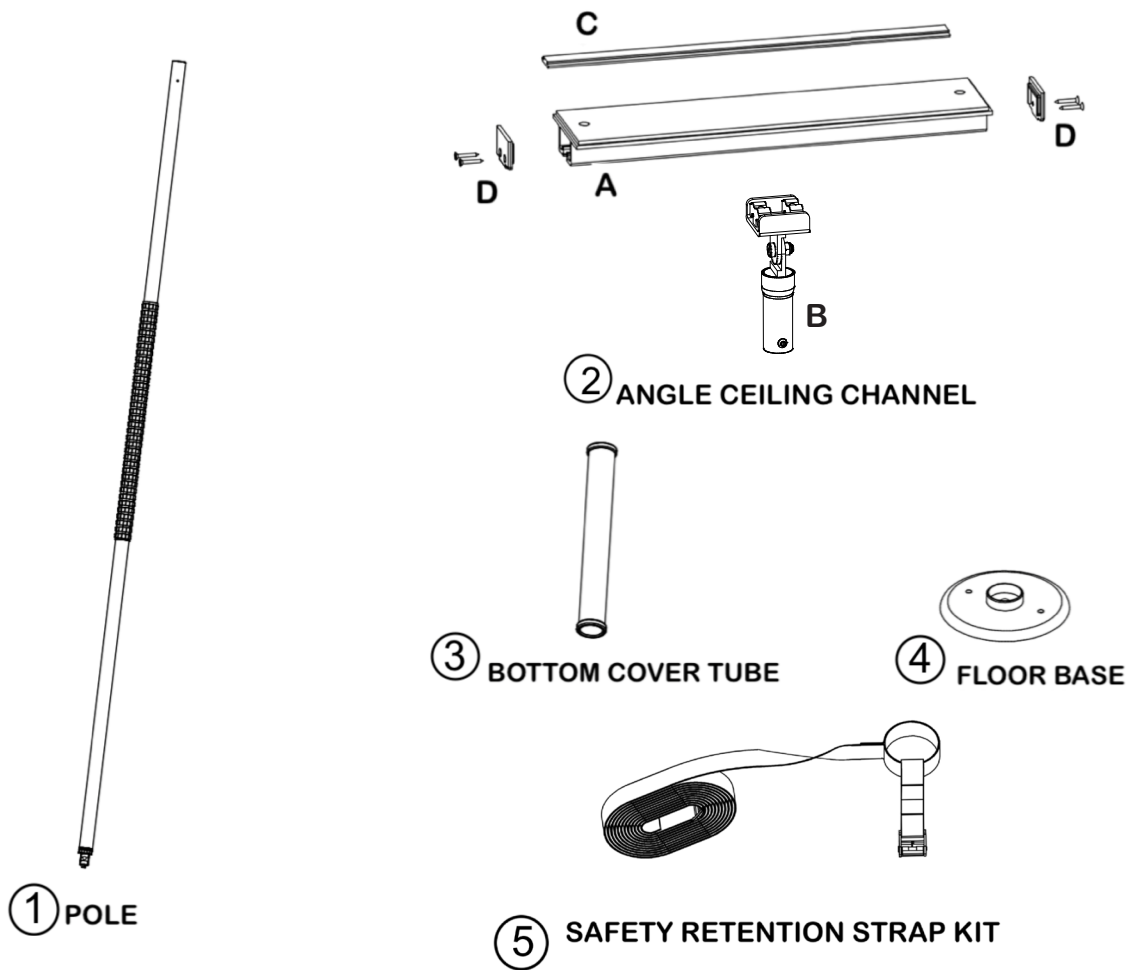

Tools Included

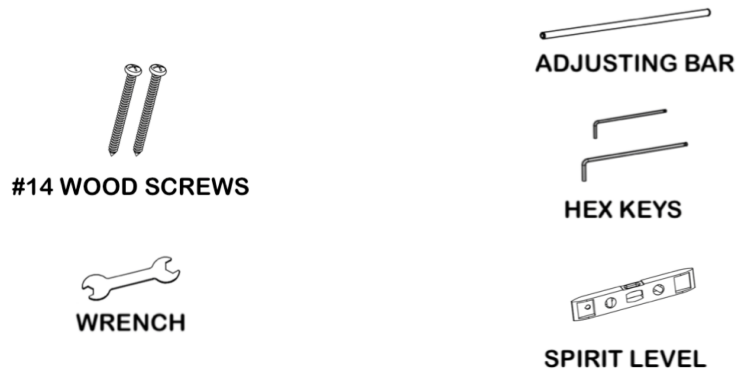

PRODUCT INFORMATION

Grab Poles feature our patented interlocking SafetyGrip® and the long-lasting protection of embedded antimicrobial AlphaSan® RC5000 silver ions powder for all parts except hardware.

For more details about AlphaSan®: <https://www.milliken.com/en-us/businesses/chemical/product/alphasan>

- The SafetyGrip® Grab Pole is an assistive device designed to assist with sit-up, reposition, balance, stand or transfers.
- Grab Poles are assistive products that may be affixed between floors and ceilings.
- The Grab Pole is a tension mount stability and positioning aid that will be subjected to significant lateral (sideway) loads when in use. It is your responsibility to ensure that the Grab Pole is correctly installed and maintained as per these **ASSEMBLY INSTRUCTIONS** provided.
- Grab Poles have 6 inches of height adjustment. For higher ceilings see the SG604 Height Adjustment Kit.
- With the addition of our SG605 Exercise Clamp Kit, the Grab Pole is excellent to offer many exercise and rehabilitation options. The SG605 Exercise Clamp Kit is fully compatible with all resistance bands, resistance straps and other rehab and exercise accessories.
- The Grab Pole is designed to assist with sit-up, reposition, balance, stand, or transfer for persons weighing up to 350lbs (158kg) and is not designed to bear the full weight of the user.

INSTALLATION

STEP 1: Assemble The Ceiling Channel

First put on safety glasses, and then you must partly assemble the Ceiling Channel. Take Part B and slide it into the end of the Ceiling Channel Part A. Tighten the two BHC Bolts in Part B to secure Part B while you are assembling the Grab Pole.

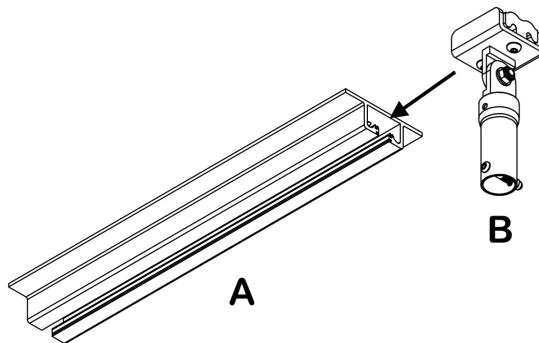

STEP 2: Join the Ceiling Channel Assembly with the Pole Upper Tube

Take the Grab Pole Item 1 and the Ceiling Channel Item 2 and slide them together. Insert the Bolt, add the Dome Nut and tighten them securely using the Hex Key and Wrench.

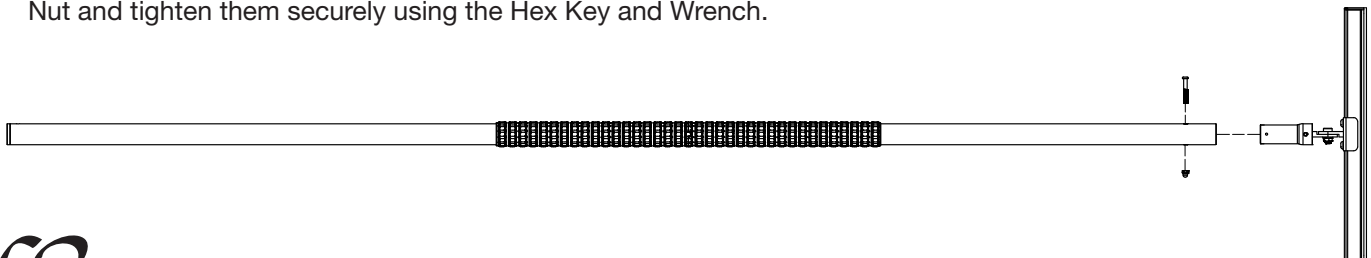

IMPORTANT: To use this Pole with a Bed

If you are installing this Grab Pole against a bed there is a risk of entrapment between the bed and the Grab Pole should the bed move away from the Pole creating a gap. Please read the Warnings and Cautions and see the Entrapment Prevention Guidelines included with this Pole Kit

You will need to install the Pole Retention Strap; open its carton and follow the Installation Instructions included.

Now is the time to slide the Strap onto the bottom of the Pole.

STEP 3: Assemble the Pole Tube

If being used, slide on the Safety Retention Strap Kit Item 5 and then slide on the Bottom Cover Tube Item 3. Have the Floor Base Item 4 ready to stand the Pole onto.

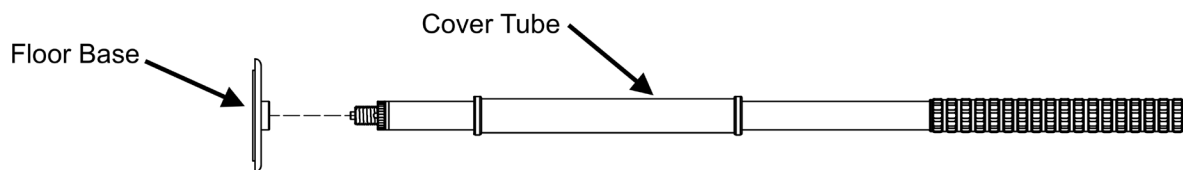

STEP 4: Locate the Ceiling Rafters

Locate the rafters behind the ceiling membrane and mark them. Using a stud finder is recommended.

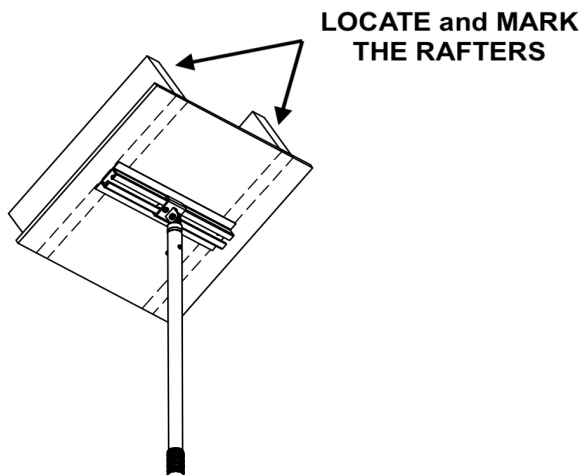

Installer Note: The Ceiling Channels are pre-drilled at 16 inch centers. If the spacing on your joists is different you will need to drill new holes in the Ceiling Channel to suit.

You are now ready to stand the Pole Assembly up between the floor and the ceiling. This is easier with two people.

STEP 5: Stand the Pole in position

Put the Grab Pole into the Floor Base Item 4 and stand it up. Align the Ceiling Channel with the marks you made in Step 4.

STEP 6: Pole Height Adjustment

You can adjust the height of the Grab Pole by turning the Bottom Screw until the Ceiling Channel is touching your Ceiling. You can use the Adjusting Bar supplied to help you do this.

Installer Note: Slide the Bottom Cover Tube Item 3 up out of your way while you are doing this step.

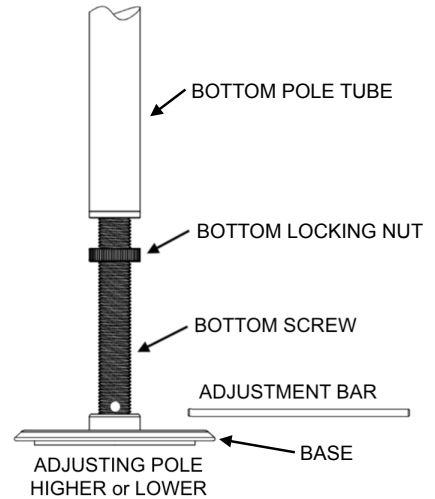

STEP 7: Screw the Ceiling Channel to the Ceiling Rafters

Move the Ceiling Channel Assembly until it is spanning the two rafters that you marked and will attach to. Mark the two holes through the Channel, one each end. Move the Channel and drill 5/32 inch pilot holes for the wood screws. Put the Channel back into position and screw the Channel to the Rafters using the wood screws supplied.

Installer Note: The Ceiling Channel has holes at 16 inch centers. If the distance between the rafters is different you will need to drill holes in the Ceiling Channel to suit your rafters.

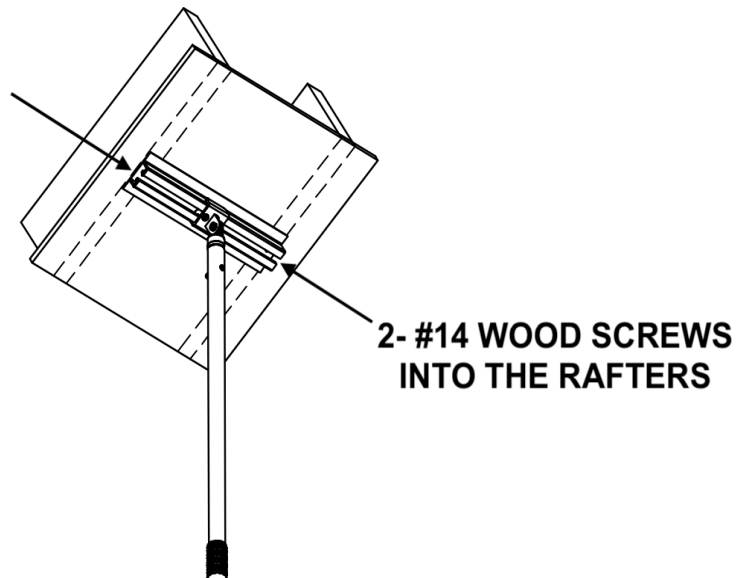

STEP 8: Pole Alignment

You can now decide where you want the Grab Pole located along the length of the Ceiling Channel.

Loosen the two BHC Bolts and move the Grab Pole and the Sliding Channel along the Ceiling Channel to where you want it, then securely re-tighten the two BHC Bolts.

Finally securely tighten the Bolt and Nut in the Angle Hinge.

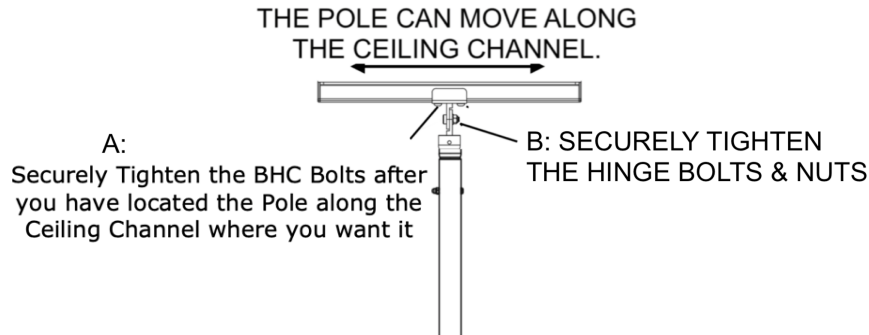

STEP 9: Final Pole Height Adjustment

You are now ready to finally tighten the Grab Pole. Before you do, check that the Grab Pole is perpendicular (90 degrees) to the floor in all directions using the level supplied. When it is perpendicular and where you want it to be, tighten the Pole using the Adjustment Bar.

Installer Caution: Do not overtighten the Grab Pole because it could damage your ceiling.

STEP 10: Add the trim parts to the Ceiling Channel

Take the Channel Trim Strip Part C, and slide into one end of the Ceiling Channel Part A. Mark it at the end of the channel, cut where the mark is and slide it back into the channel. Repeat this on the other side of the channel. Now screw the two plastic End Caps Part D onto each end of the channel using a philips screw driver.

Installer Note: You can cut the Channel Trim Strips using strong scissors or a fine blade hack-saw.

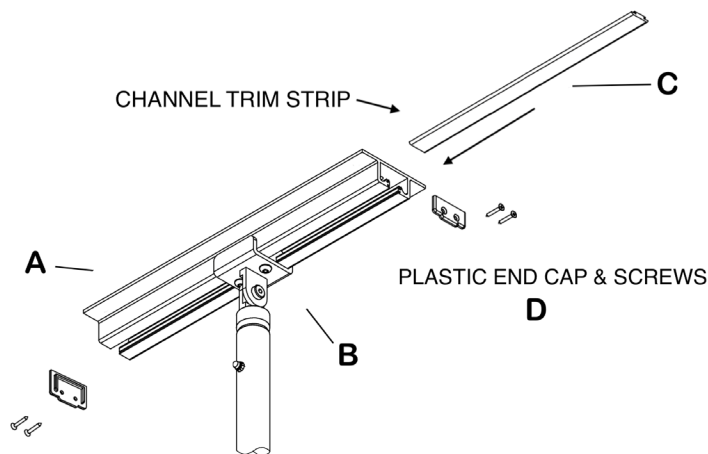

STEP 11: Final Checks

Ensure the Grab Pole is safe and secure by grasping the Pole mid-height and push and pull vigorously. The Base or Ceiling Channel should not slide or move if the Grab Pole is tensioned correctly.

When the Grab Pole is tight and secure, tighten the Bottom Locking Nut against the bottom of the Grab Pole using the Adjustment Bar.

MAINTENANCE AND CLEANING

- **VERY IMPORTANT:** It is important to inspect the Product(s) frequently.
- Stop using immediately if damaged or broken, or if parts are missing.
- Stop using immediately if Product(s) shift out of the original installed position(s) until they are readjusted into the correct position.
- To clean your Grab Pole, use a damp cloth with soap and water or mild household cleaner, wipe clean and dry before using.



Hartmobility reserves the right to update and revise our products. Refer to our website for the most up-to-date version of this document.

Copyright © 2024 Hartmobility Inc. All Rights Reserved.

